



GENUINE PARTS

INSTALLATION INSTRUCTIONS

DESCRIPTION: Hood Protector

APPLICATION: Pathfinder

PART NUMBER: 999D5 X2100

KIT CONTENTS:

Item	Qty.	Part Description	Service Part Number
A	1	Hood Protector	---
B	2	Center Clip	---
C	2	Outer Clip	---
D	2	Stick-on Wing Clip	---
E	6	Small Screw	---
F	6	Fibre Washer	---
G	6	Abrasive Tape	---
H	4	Neoprene Washer (Rectangle)	---
I	4	Large Screw	---
J	4	Plastic Washer	---
K	1	Screw Plug	---
L	1	Alcohol Wipe (2-pk)	---
M	1	Installation Instruction Replacement Template	999V2 AW000
N	1	Template	---

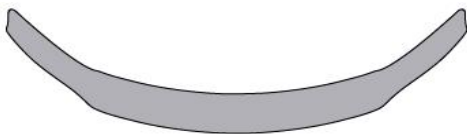

A

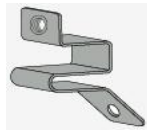

B



C

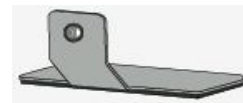

D



E

F



G



H



I



J



K

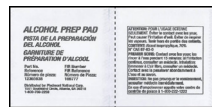

L



M

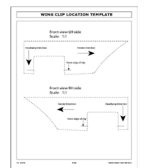

N

TOOLS REQUIRED:

- Drill
- Clean Cloth
- 5/16" (8mm) Drill Bit
- Non-Permanent Marker / Pencil
- Masking Tape
- Soapy Water
- #2 Phillips Screwdriver
- Clip Removal Tool / Flathead Screwdriver

INSTALLATION CAUTIONS / NOTES:

- Before installation clean hood surface with mild soap and water using a soft cloth or chamois.
- Never use ammonia based cleaners or solvents on the hood protector
- Dealer Installation Recommended.
- Allow tape to cure for 4 hours before driving vehicle.

INSTALLATION PROCEDURE:

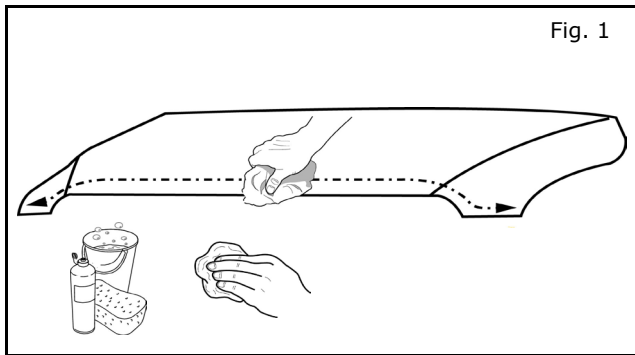

- 1) Clean hood installation area using soapy water and clean cloth.

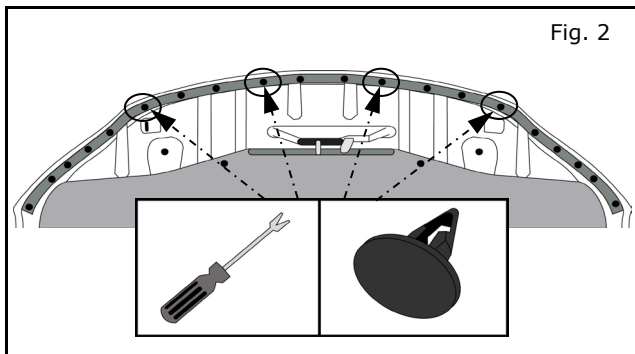

- 2) Open hood.
- 3) Cover engine compartment with protective blanket to catch any dropped hardware.
- 4) Remove 4 grommets using clip removal tool or flathead screwdriver.

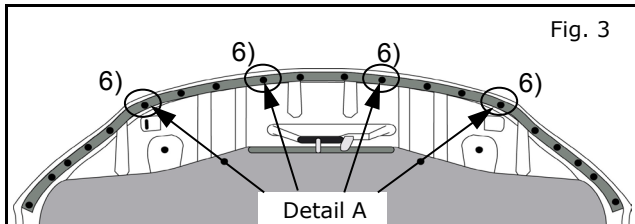

- 5) Attach masking tape to drill bit 6mm from end.
- 6) Enlarge existing holes using 5/16" (8mm) drill bit at 4 locations shown.

Note: Make sure drill is on low speed and do not use excessive force.

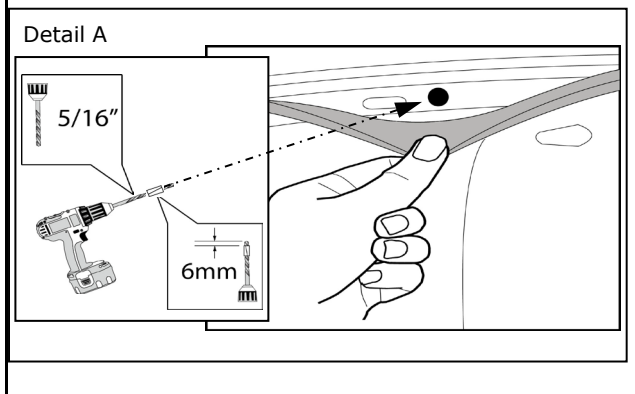

- 7) Remove any metal shavings and burrs from drilled holes.

INSTALLATION PROCEDURE:

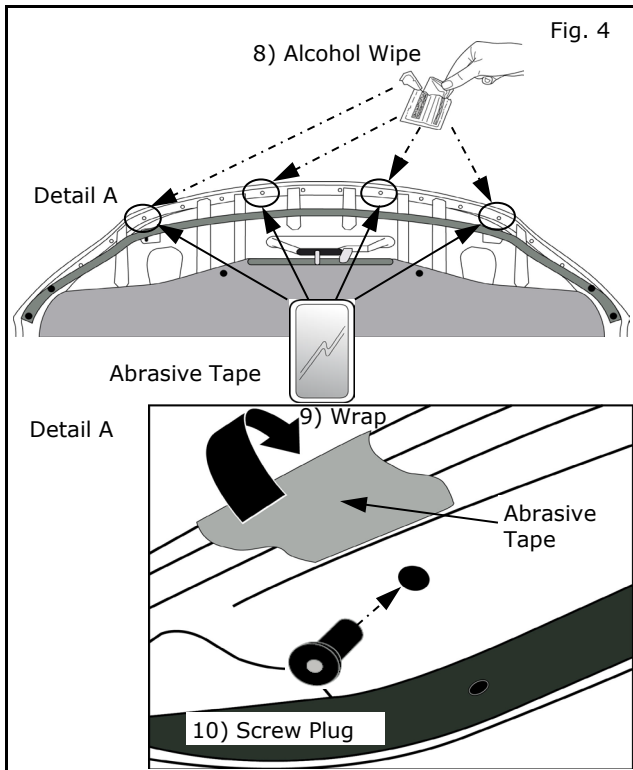

- 8) Clean top and underside of hood areas adjacent to holes with alcohol wipes.
- 9) Wrap abrasive tape over hood lip.
Note: To protect vehicle from clip, apply tape so that half of tape is on the topside and half is on the underside of hood.
- 10) Insert screw plugs into 4 previously drilled out holes.

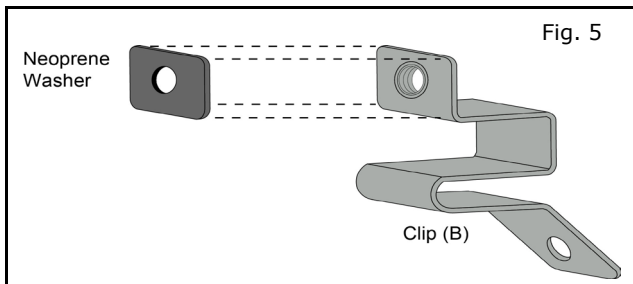

- 11) Peel backing off neoprene washers.
- 12) Fix neoprene washers to clips (B, C and D).
Note: As shown in Fig. 5 (clip B).

INSTALLATION PROCEDURE:

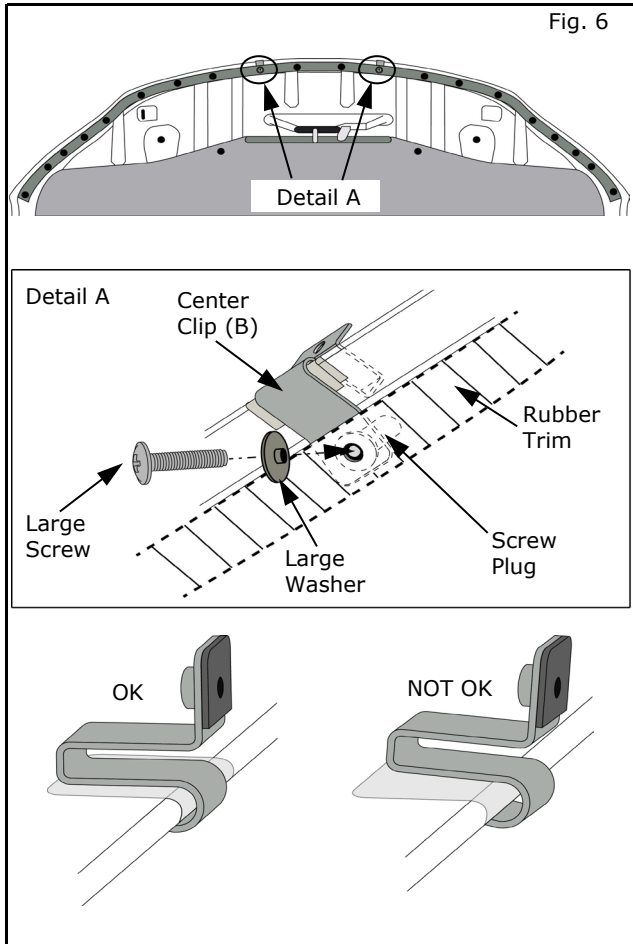

- 13) Slide center clips (B) onto hood under rubber trim and secure using the large screw through large washer, rubber trim and brackets into previously installed screw plug.

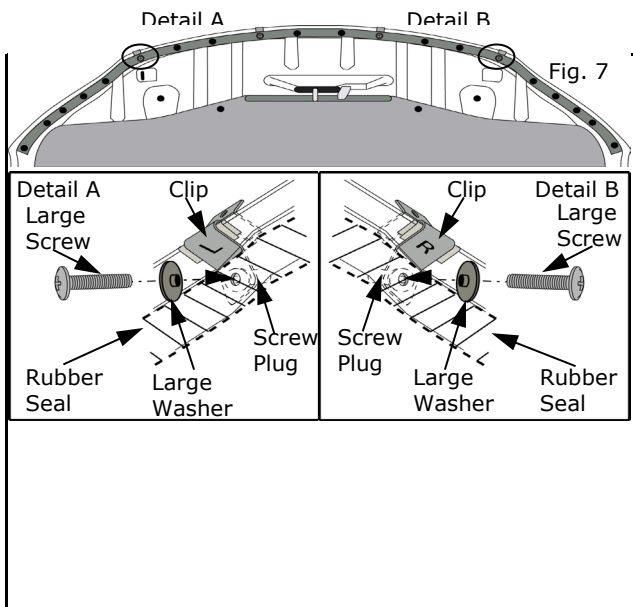

- 14) Secure left and right clips (C) onto hood under rubber trim and secure using large screw through large washer, rubber trim and brackets into previously installed screw plug.

Note: Right and Left clips are identified (R, L). Center clips (B) have no markings.

- 15) Remove protective blanket and close hood.

INSTALLATION PROCEDURE:

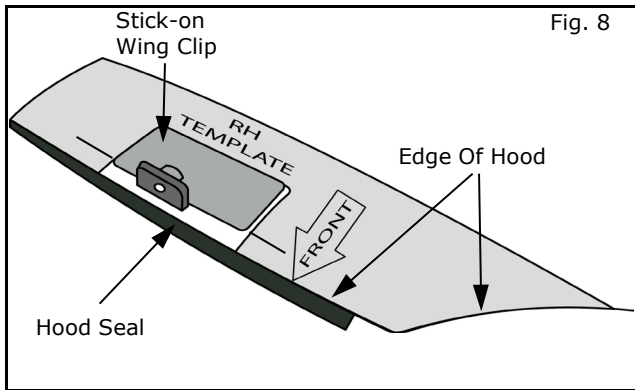

Fig. 8

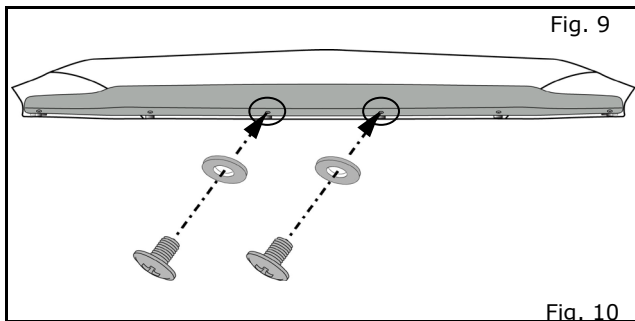

Fig. 9

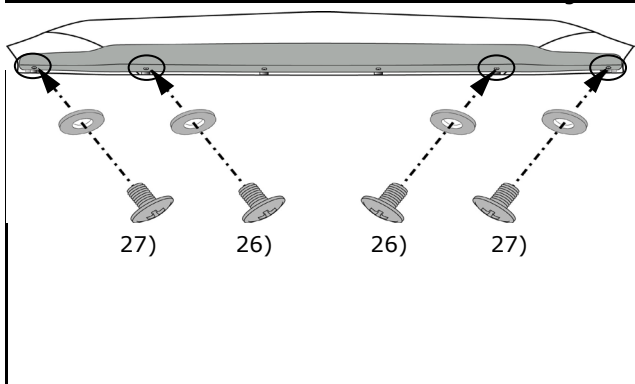

Fig. 10

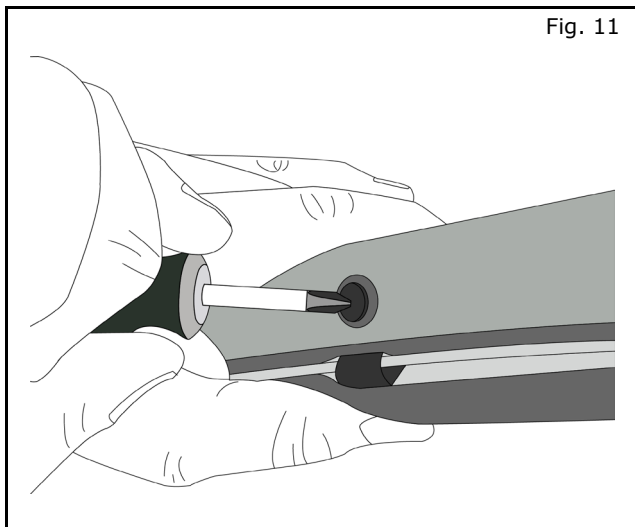
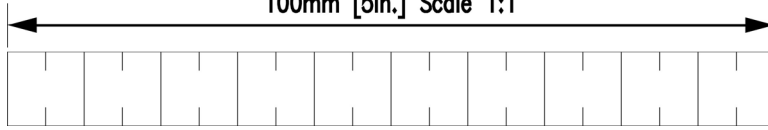

Fig. 11

- 16) Cut out Templates for stick-on wing clip.
- 17) Position on hood by aligning to front and outer edge of hood.
- 18) Secure with masking tape.
- 19) Peel adhesive backing of stick-on wing clips (D).
- 20) Attach stick-on wing clip (D) to hood at marked location on template.
- 21) Apply at least 15lbs of pressure for at least 10 seconds to secure stick-on wing clip to hood.
- 22) Remove and discard templates.
- 23) Open hood and replace protective blanket.
- 24) Insert small screws through fibre washers into center
Note: Do not fully tighten screws.
- 25) Insert small screws through fibre washers and into outer clips.
Note: Do not fully tighten screws.
- 26) Insert small screws through fibre washers and into stick-on wing clips.
Note: Do not fully tighten screws.
- 27) Check to see that the hood protector is centrally located, adjust as necessary.
- 28) Squeeze hood protector to hood to eliminate any gap while fully tightening each screw.
- 29) Remove protective blanket and close hood.

TEMPLATE:

100mm [5in.] Scale 1:1



180.5mm [7in.] (REF)

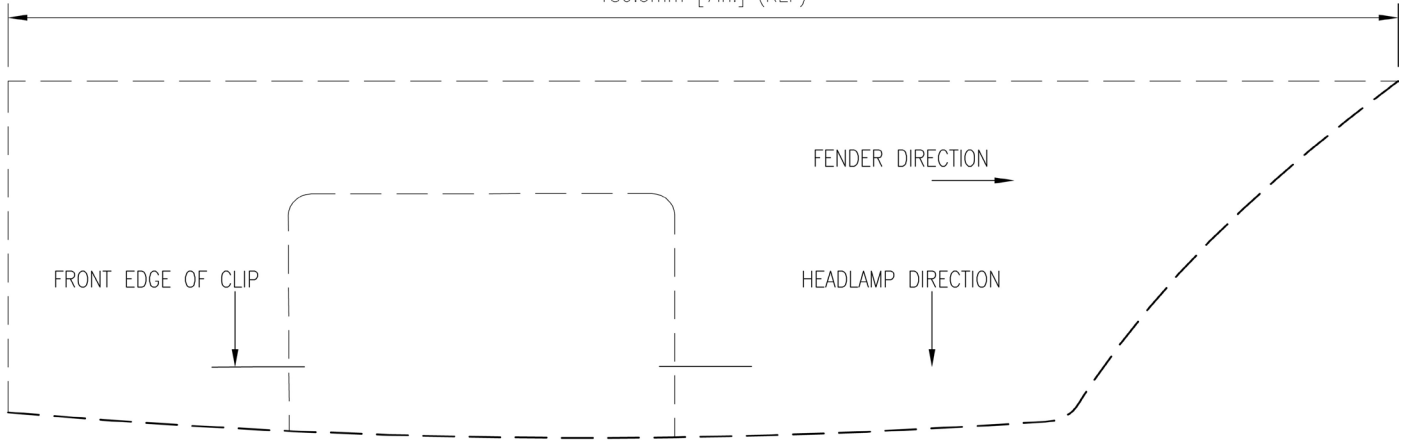

180.7mm [7in.] (REF)

